

BS 5153 PN16 CAST IRON SWING CHECK VALVE WITH WEIGHT

TECHNICAL REQUIREMENT :

- Design and Manufacture Conform to EN12334, BS5153
- Flange dimensions Conform to EN1092-2 PN16
- Face to Face dimensions Conform to EN558-1 List 10, BS5153
- Testing Conform to EN12266-1
- CI-GREY CAST IRON, DI-DUCTILE IRON

MATERIALS OF PARTS

NO.	PART NAME	MATERIAL
1	BODY	EN-GJL-250/EN-GJS-500-7
2	SEAT RING	ASTM B62 C83600
3	DISC	EN-GJL-250/EN-GJS-500-7
4	DISC RING	ASTM B62 C83600
5	HINGE	ASTM A536 65-45-12
6	STEM	ASTM A276 410
7	BONNET	EN-GJL-250/EN-GJS-500-7
8	LEVER	CARBON STEEL
9	WEIGHT	CAST IRON

NOTE: Above 5 inch have eyebolt

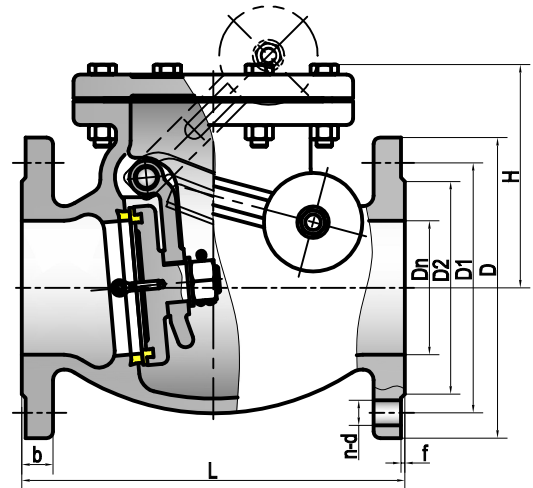

Fig No. :CHV402-PN16

DIMENSIONS DATA (MM)

DN	50	65	80	100	125	150	200	250	300	350	400	450	500	600	
L	203	216	241	292	330	356	495	622	699	787	914	965	1016	1219	
D	CI	165	185	200	220	250	285	340	405	460	520	580	640	715	840
	DI								400	455					
D1	125	145	160	180	210	240	295	355	410	470	525	585	650	770	
D2	99	118	132	156	184	211	266	319	370	429	480	548	609	720	
b	CI	20	20	22	24	26	26	30	32	32	36	38	40	42	48
	DI	19	19	19	19	19	19	20	22	24.5	26.5	28	30	31.5	36
n-d	4-19	4-19	8-19	8-19	8-19	8-23	12-23	12-28	12-28	16-28	16-31	20-31	20-34	20-37	
f	3	3	3	3	3	3	3	3	4	4	4	4	4	5	
H	124	129	153	170	196	259	332	383	425	450	512	702	755	856	