

MSS SP-71 CLASS 125 CAST IRON SWING CHECK VALVE

TECHNICAL REQUIREMENT :

- Design and Manufacture Conform to MSS SP-71
- Flange dimensions Conform to ASME B16.1
- Face to Face dimensions Conform to ASME B16.10
- Testing Conform to MSS SP-71



MATERIALS OF PARTS

NO.	PART NAME	MATERIAL
1	BODY	ASTM A126 B
2	SEAT RING	ASTM B62 C83600
3	DISC	ASTM A126 B
4	DISC RING	ASTM B62 C83600
5	HINGE	ASTM A536 65-45-12
6	STEM	ASTM A276 410
7	BONNET	ASTM A126 B

NOTE: Above 6 inch have eyebolt

Fig No. :CHV101-125

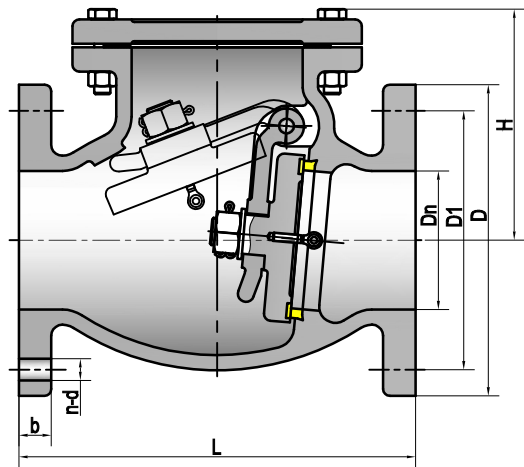

DIMENSIONS DATA (MM)

NPS	2	2½	3	4	5	6	8	10	12	14	16	18	20	24
Dn	51	63.5	76	102	127	152	203	254	305	356	406	457	508	610
L	203.2	215.9	241.3	292.1	330.2	355.6	495.3	622.3	698.5	787.4	914.4	965	1016	1219
D	152	178	191	229	254	279	343	406	483	533	597	635	699	813
D1	120.7	139.7	152.4	190.5	215.9	241.3	298.5	362	431.8	476.3	539.8	577.9	635	749.3
b	15.8	17.5	19	23.9	23.9	25.4	28.5	30.2	31.8	35	36.6	39.6	42.9	47.8
n-d	4-19	4-19	4-19	8-19	8-22	8-22	8-22	12-25	12-25	12-29	16-29	16-32	20-32	20-35
H	124	129	153	170	196	259	332	383	425	450	512	702	755	856