

PN25 Y-STRAINER

TECHNICAL REQUIREMENT :

- Face to Face dimensions Conform to EN558-1 list 1
- Flange dimensions Conform to EN1092-2 PN25
- Testing Conform to EN12266-1

NOTE: 1.DN50~DN300 meshes $\Phi 1.5$
 DN350~DN600 meshes $\Phi 3.0$
 2.It can be manufactured according to customer's requirement
 3.DN450~DN600 Body and bonnet's materials are EN-GJS-450-10



Fig No. :STR801-PN25

MATERIALS OF PARTS

NO.	PART NAME	MATERIAL
1	BODY	EN-GJS-450-10
2	SCREEN	SS304
3	BONNET	EN-GJS-450-10
4	PLUG	MALLEABLE CAST IRON
5	BONNET GASKET	GRAPHITE +08F

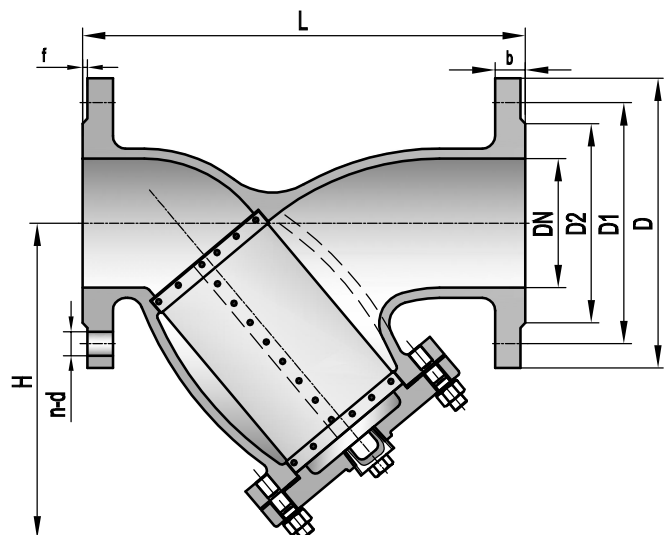

DIMENSIONS DATA (MM)

DN	50	65	80	100	125	150	200	250	300	350	400	450	500	600
L	230	290	310	350	400	480	600	730	850	980	1100	1200	1250	1450
D	165	185	200	235	270	300	360	425	485	555	620	670	730	845
D1	125	145	160	190	220	250	310	370	430	490	550	600	660	770
D2	99	118	132	156	184	211	274	330	389	448	503	548	609	720
b	19	19	19	19	19	20	22	24.5	27.5	30	32	34.5	36.5	42
n-d	4-19	8-19	8-19	8-23	8-28	8-28	12-28	12-31	16-31	16-34	16-37	20-37	20-37	20-41
f	3	3	3	3	3	3	3	3	4	4	4	4	4	5
H	152	186.5	203	250	288	325	405	496	574	660	727	826.5	884	1022